

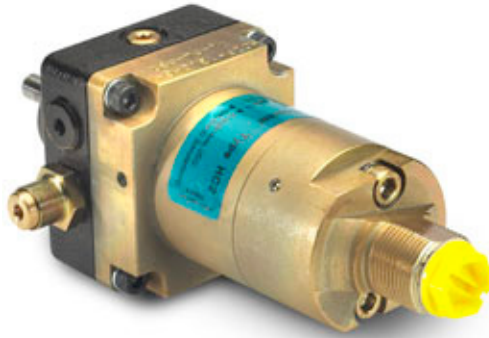

- Description
- Flow rates
- Dimensions
- Functions
- Connection types
- Max tightening torque BSP
- Fluids and materials
- Ordering number

The HC2P miniBOOSTER



Booster Pump

HC2P versions: 10 different intensification factors

P_{IN}: 0.4 bar vacuum to 2 bar in suction line (inlet pressure)

P_H: 800 bar maximum (outlet pressure)

Intensification ratios: $P_H = (P_{IN} - P_{Return}) \cdot i$
(Intensification)

Mounting: Inline tube

Rotation speed: Minimum 1,200 min⁻¹ / maximum 3,000 min⁻¹

Starting torque: Max. starting torque 0.14 Nm

Power Consumption: 87 W

Accessories: Pilot operated dump valve available

A model = no dump valve

G model = direct proportionally controlled

▲ Description of the HC2P miniBOOSTER hydraulic intensifier

The HC2P is a self priming Booster Pump supplying a pressure up to 800 bar. It is ideal for use in a variety of [applications](#) where no hydraulic system is available. The Booster Pump is a combination of a gear pump and the HC2 miniBOOSTER.

Like [other miniBOOSTER models](#), the HC2P automatically compensates for consumption of oil to maintain the high pressure. Adjustment of the outlet pressure is carried out on the low-pressure side (gear pump). Relative to its flow capability, the HC2P is a compact unit weighting only 2.1 kg.

▲ Flow Rates

Intensification factor <i>i</i>	Max. outlet flow l/min	Max. outlet pressure bar
1.2	0.12	60
1.5	0.10	75
2.0	0.08	100
2.8	0.06	140
3.2	0.25	160
4.0	0.20	200
5.0	0.16	250
6.6	0.13	330
9.0	0.09	450
13.0	0.06	650

▲ Dimensions

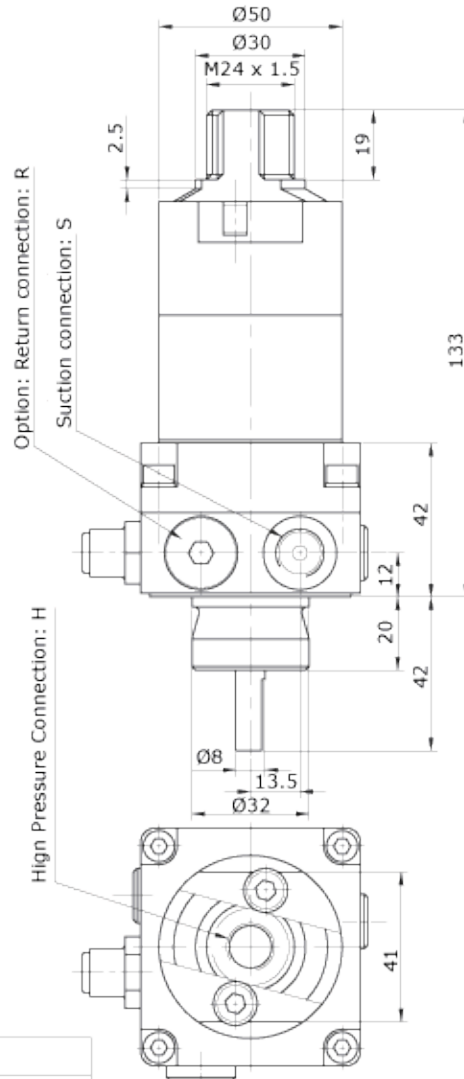
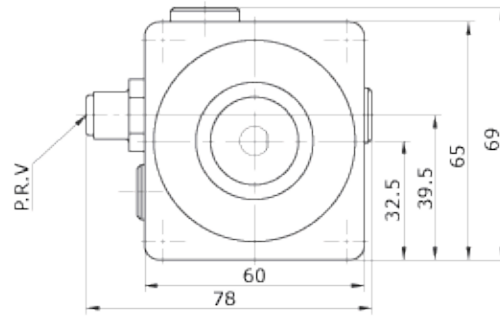

	S&R	H
1	1/4" BSP	1/4" BSP

▲ **Functions**

The basic operation is illustrated in the function diagram. From the suction inlet oil is drawn into the gear set of the pump, where the pressure is increased to approx. 40 bar and fed to the IN port of the booster, where it flows freely through the check valves RV, KV1 and KV2 to the high pressure side H.

When end pressure is reached on the high pressure side H, valves KV1 and KV2 will close. The end pressure will be achieved by the oscillating pump unit OP. If there is a pressure drop on the high pressure side due to consumption or leakage, the OP valve will automatically operate to maintain the end pressure.

When the pump is stopped, there will be no pressure on the IN-port and Pilot Supply 2, causing the RV to open allowing the fluid to return to the tank

Function Diagram

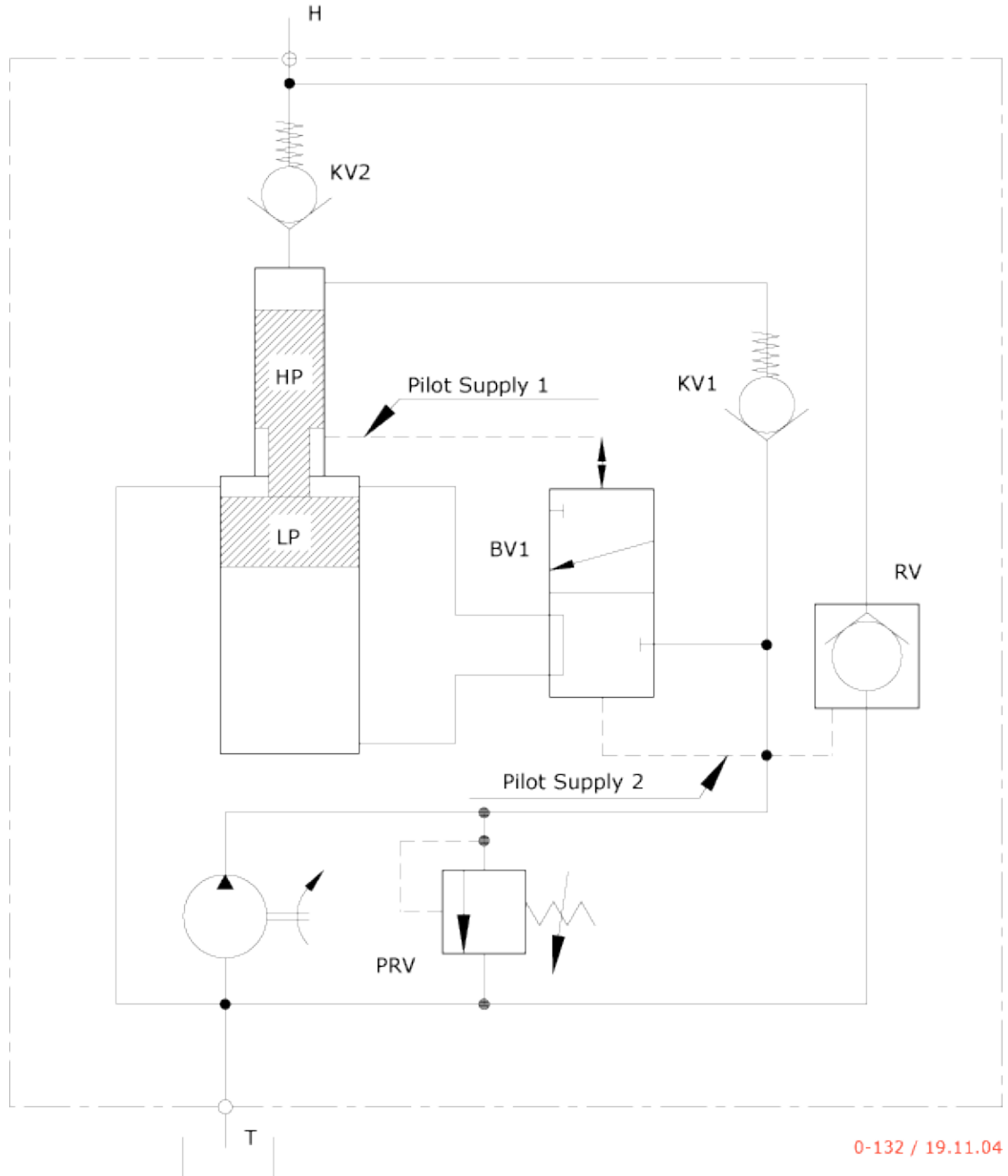

▲ **Connection types**

Connection	H / S
1	1/4" BSP

▲ **Max. tightening torque BSP**

	H / S
	1/4" BSP
with steel washer	4.0 da/Nm
with aluminium washer	3.0 da/Nm
with cutting edge	4.0 da/Nm

▲ **Fluids and materials**

Please see [General Specifications](#).

▲ **Ordering a HC2P**

Ordering example of a HC2P with i = 9.0, DV incorporated and BSP connections:
 HC2P - 9.0 - G - 1



Model	Intensification, i	Dump Valve	Connections
HC2P	your selection...	your selection...	your selection...
	see flow rate table	A = (no) / A model	1
		G = (proportional) / G model	