



- Description
- Flow rates
- Dimensions
- Functions
- Connection types
- Max tightening torque BSP
- Max tightening torque UNF
- Fluids and materials
- Ordering number

The HC2 miniBOOSTER



HC2 versions: 11 different intensification factors

P_{IN}: 20 – 200 bar (inlet pressure)

P_H: 800 bar maximum (outlet pressure)

P_{RETURN}: As low as possible (Return pressure to tank)

Intensification ratios: $P_H = (P_{IN} - P_{Return}) \cdot i$
 (Intensification)

Mounting: Inline tube

Accessories: Pilot operated dump valve available

A model = no dump valve

B model = with dump valve

G model = direct proportionally controlled

▲ Description of the HC2 miniBOOSTER hydraulic intensifier

The HC2 is a compact unit weighing only 1.0 kg. It is ideal for use in a variety of applications where building and maintaining high pressure is required.

The HC2 raises supplied pressure to a higher outlet pressure and automatically compensates for consumption of oil to maintain the high pressure. Adjustment of the outlet pressure is carried out by varying the supplied pressure.

▲ Flow Rates

Intensification factor i	Max. outlet flow l/min	Max. inlet flow l/min
1.2	1.2	8.0
1.5	1.0	8.0
2.0	2.0	12.0
2.8	2.2	13.0
3.2	2.5	15.0
4.0	2.0	14.0
5.0	1.6	14.0
6.6	1.3	13.0
9.0	0.9	13.0
13.0	0.6	12.0
20.0	0.3	12.0

▲ **Dimensions**

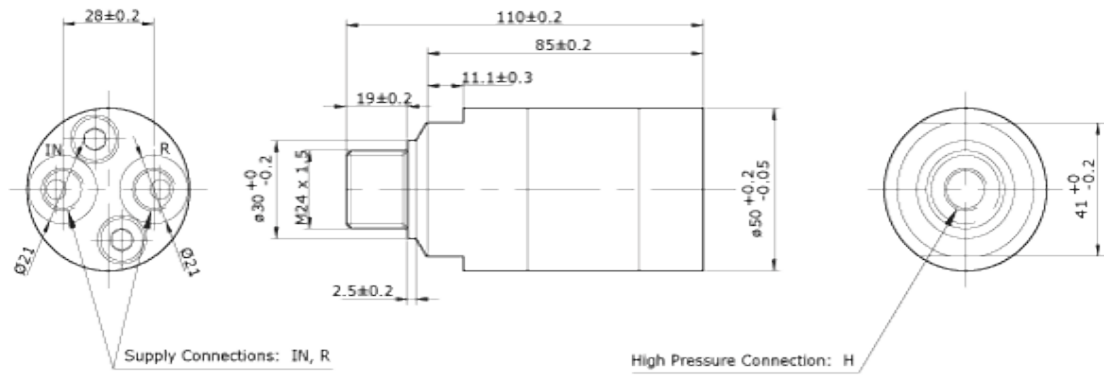

	IN, R	H
1	1/4" BSP	1/4" BSP
2	7/16"-20 UNF	9/16"-18 UNF

2-120 / 03.10.02

▲ **Functions**

The basic operation is illustrated in the function diagram. Oil is fed through the directional valve CV to the IN port, flowing freely through the check valves KV1, KV2 and DV to the high pressure side H. In this condition maximum flow through the booster is achieved giving a fast forward function.

When pump pressure is reached on the high pressure side H, valves KV1, KV2 and DV will close. The end pressure will be achieved by the oscillating pump unit OP. The unit will automatically stall when end pressure on high pressure side H is reached. If there is a pressure drop on the high pressure side due to consumption or leakage, the OP valve will automatically operate to maintain the end pressure.

Function Diagram

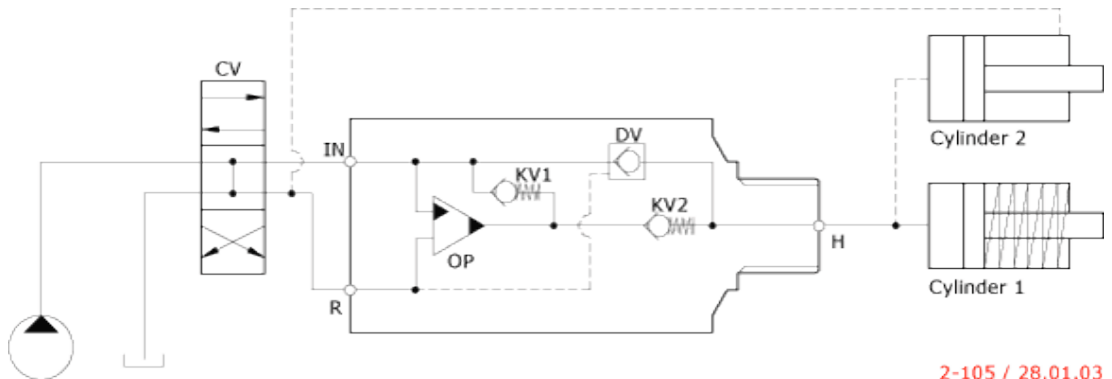

2-105 / 28.01.03

▲ **Connection types**

Connection	IN / R	H
1	1/4" BSP	1/4" BSP
2	7/16-20 UNF	9/16-18 UNF

▲ **Max. tightening torque BSP**

	IN / R	H
	1/4" BSP	1/4" BSP
with steel washer	4.0 da/Nm	4.0 da/Nm
with aluminium washer	3.0 da/Nm	-
with cutting edge	4.0 da/Nm	4.0 da/Nm

▲ **Max. tightening torque UNF**

	IN / R	H
	7/16-20" UNF	9/16-18" UNF
with o-ring	2.0 da/Nm	3.5 da/Nm

▲ **Fluids and materials**

Please see [General Specifications](#).

▲ **Ordering a HC2**

Ordering example of a HC2 with $i = 4.0$,
DV incorporated and BSP connections: HC2 - 4.0 - B - 1

Model	Intensification, i	Dump Valve	Connections
HC2	your selection...	your selection...	your selection...
	see flow rate table	A = (no) / A model	1
		B = (yes) / B model	2
		G = (proportional) / G model	

ISO 9001
BUREAU VERITAS
Certification

