



- Description
- Flow rates
- Dimensions
- Functions
- Connection types
- Max tightening torque BSP
- Max tightening torque UNF
- Fluids and materials
- Ordering number

The HC2D miniBOOSTER



Up to 2.5 times the volume

HC2D versions: 12 different intensification factors

P_{IN}: 20 – 200 bar (inlet pressure)

P_H: 800 bar maximum (outlet pressure)

P_{RETURN}: As low as possible (Return pressure to tank)

Intensification ratios: $P_H = (P_{IN} - P_{RETURN}) \cdot i$
 (Intensification)

Mounting: Inline tube

Accessories: Pilot operated dump valve available

A model = no dump valve

B model = with dump valve

G model = direct proportionally controlled

▲ Description of the HC2D miniBOOSTER hydraulic intensifier

The HC2D is a high flow dual acting unit which is capable of up to 11.0 l/min flow on the high pressure end. Like other miniBOOSTER models, the HC2D raises supplied pressure to a higher outlet pressure and automatically compensates for consumption of oil to maintain the high pressure. Adjustment of the outlet pressure is carried out by varying the supplied pressure. Relative to its flow capability, the HC2D is a compact unit weighing 3.8 kg.

▲ Flow Rates

Intensification factor i	Max. outlet flow l/min	Max. inlet flow l/min
1.2	11.0	15.0
1.6	10.2	15.0
1.9	8.8	15.0
2.2	7.8	15.0
2.6	7.0	15.0
3.2	6.2	15.0
4.0	5.0	14.0
5.0	4.0	14.0
6.6	3.2	13.0
9.0	2.2	13.0
13.0	1.5	12.0
20.0	0.7	12.0

▲ **Dimensions**

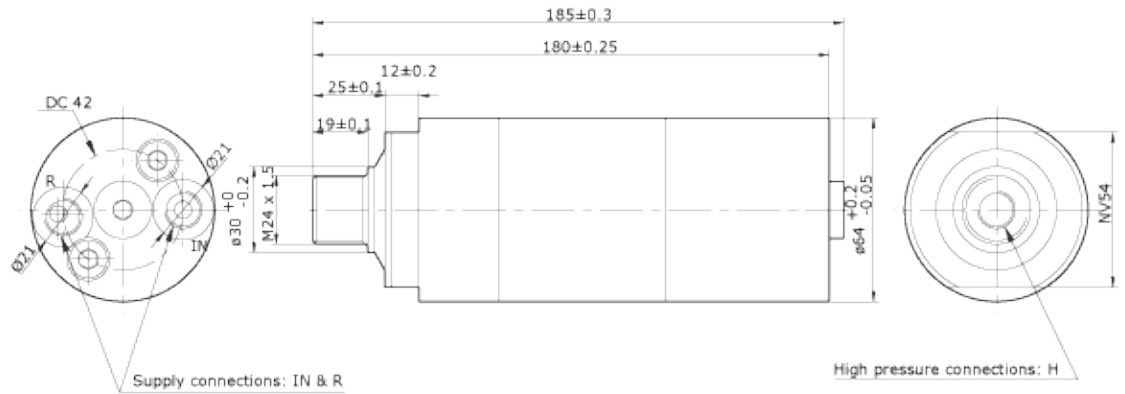

	IN & R	H
1	1/4" BSP	1/4" BSP
2	9/16"-18 UNF	9/16"-18 UNF

2D-120 / 24.10.02

▲ **Functions**

The basic operation is illustrated in the function diagram. Oil is fed through the directional valve CV to the IN port, flowing freely through the check valves 2x KV1, 2x KV2 and DV to the high pressure side H. In this condition maximum flow through the booster is achieved giving a fast forward function.

When pump pressure is reached on the high pressure side H, valves KV1, KV2 and DV will close. The end pressure will be achieved by the oscillating pump units OP1 and OP2 by turns. The unit will automatically stall when end pressure on high pressure side H is reached. If there is a pressure drop on the high pressure side due to consumption or leakage, the OP1 and OP2 units will automatically operate to maintain the end pressure. It is possible to change the high pressure R connection H to the opposite end of the booster.

Function Diagram

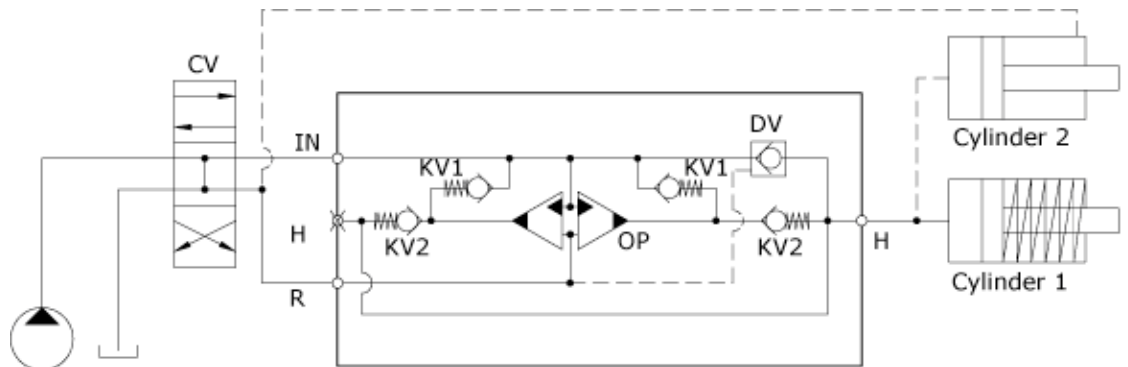

2D-105 / 09.01.03

▲ **Connection types**

Connection	IN / R	H
1	1/4" BSP	1/4" BSP
2	9/16-18 UNF	9/16-18 UNF

▲ **Max. tightening torque BSP**

	IN / R	H
	1/4" BSP	1/4" BSP
with steel washer	4.0 da/Nm	4.0 da/Nm
with aluminium washer	3.0 da/Nm	-
with cutting edge	4.0 da/Nm	4.0 da/Nm

▲ **Max. tightening torque UNF**

	IN / R	H
	7/16-18" UNF	9/16-18" UNF
with o-ring	2.0 da/Nm	3.5 da/Nm

▲ **Fluids and materials**

Please see [General Specifications](#).

▲ **Ordering a HC2D**

Ordering example of a HC2D with i = 4.0, DV incorporated and BSP connections:
HC2D - 4.0 - B - 1

Model	Intensification, i	Dump Valve	Connections
HC2D	your selection... see flow rate table	your selection... A = (no) / A model B = (yes) / B model G = (proportional) / G model	your selection... 1 2

