



- Description
- Flow rates
- Dimensions
- Functions
- Connection types
- Max tightening torque BSP
- Max tightening torque UNF
- High pressure adapters
- Fluids and materials
- Ordering number

## The HC7W miniBOOSTER



**HC7W versions:** 5 different intensification factors

**P<sub>IN</sub>:** 20 – 200 bar (inlet pressure)

**P<sub>H</sub>:** 2000 bar maximum (outlet pressure)

**P<sub>RETURN</sub>:** As low as possible (Return pressure to tank)

**Intensification ratios:**  $P_H = (P_{IN} - P_{Return}) \cdot i$   
(Intensification)

**Mounting:** Inline tube

**Accessories:** Pilot operated dump valve incorporated

A model = no dump valve

B model = with dump valve

G model = direct proportionally controlled

### ▲ Description of the HC7W miniBOOSTER hydraulic intensifier

The HC7W is a very compact high pressure unit capable of delivering pressure up to 2000 bar with an weight of only 1.5 kg. It is ideal for use with very thin (low viscosity) medias. It is ideal for use in portable applications like on [power packs](#).

The HC7W raises supplied pressure to a higher outlet pressure and automatically compensates for consumption of oil to maintain the high pressure. Adjustment of the outlet pressure is carried out by varying the supplied pressure. With the choice of different high pressure adapters a variety of threads can be obtained from the M22x1.5 thread in the HP port.

### ▲ Flow Rates

Intensification factor i	Max. outlet flow l/min	Max. inlet flow l/min
5.0	1.6	14.0
6.6	1.3	13.0
9.0	0.9	13.0
13.0	0.6	12.0
20.0	0.3	12.0

▲ **Dimensions**

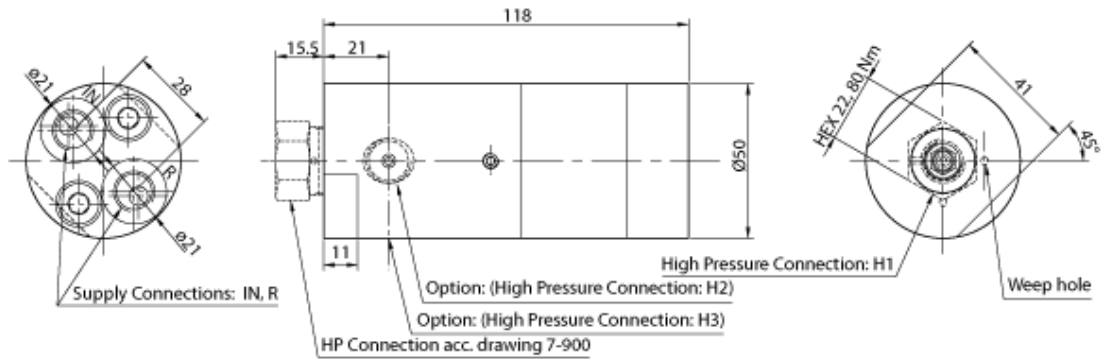

miniBOOSTER HC7 Intensifier:

Ordering code	IN, R	H1	H2	H3
HC7-...-11	1/4" BSP	M22 x 1.5	-	-
HC7-...-21	7/16-20 UNF	M22 x 1.5	-	-
HC7-...-12	1/4" BSP	M22 x 1.5	9/16-18 UNF	
HC7-...-22	7/16-20 UNF	M22 x 1.5	9/16-18 UNF	
HC7-...-13	1/4" BSP	M22 x 1.5	9/16-18 UNF	9/16-18 UNF
HC7-...-23	7/16-20 UNF	M22 x 1.5	9/16-18 UNF	9/16-18 UNF

7-120 / Issue 7

▲ **Functions**

The basic operation is illustrated in the function diagram. Media is fed through the directional valve CV to the IN port, flowing freely through the check valves KV1, KV2 and DV to the high pressure side H. In this condition maximum flow through the booster is achieved giving a fast forward function.

When pump pressure is reached on the high pressure side H, valves KV1, KV2 and DV will close. The end pressure will be achieved by the oscillating pump unit OP. The unit will automatically stall when end pressure on high pressure side H is reached. If there is a pressure drop on the high pressure side due to consumption or leakage, the OP valve will automatically operate to maintain the end pressure.

Function Diagram

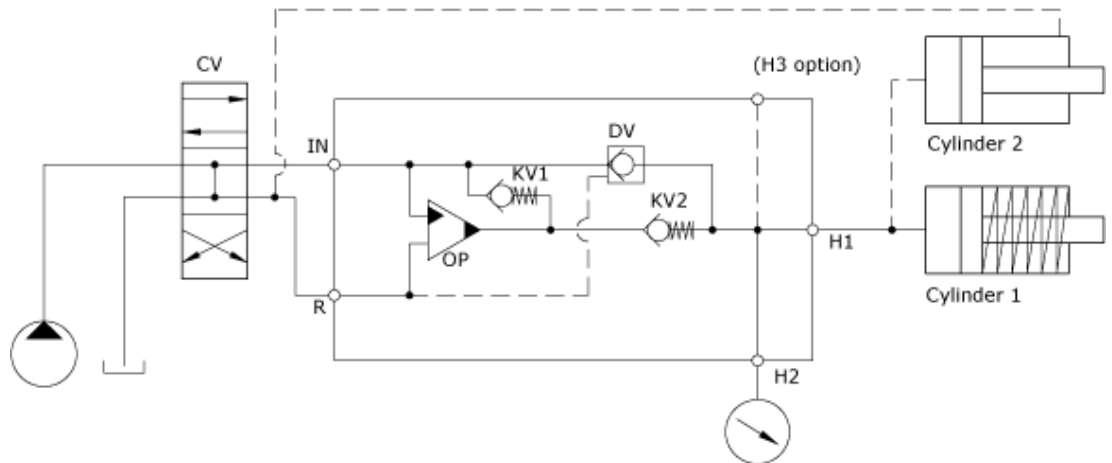

7-105 / 29.08.06

▲ **Connection types**

Connection	IN / R
1	1/4" BSP
2	7/16-20" UNF

▲ **Max. tightening torque BSP**

	IN / R
	1/4" BSP
with steel washer	4.0 da/Nm
with aluminium washer	3.0 da/Nm
with cutting edge	4.0 da/Nm

▲ **Max. tightening torque UNF**

	IN / R
	7/16-20" UNF
with o-ring	2.0 da/Nm

▲ **High pressure adapters**

Ordering Code	Male connection 1	Female connection 2
7W-432	M22 x 1.5	9/16-18 UNF
7W-433	M22 x 1.5	1/4" BSP
7W-434	M22 x 1.5	Plug
7W-437	9/16-18 UNF	M12 x 1.5

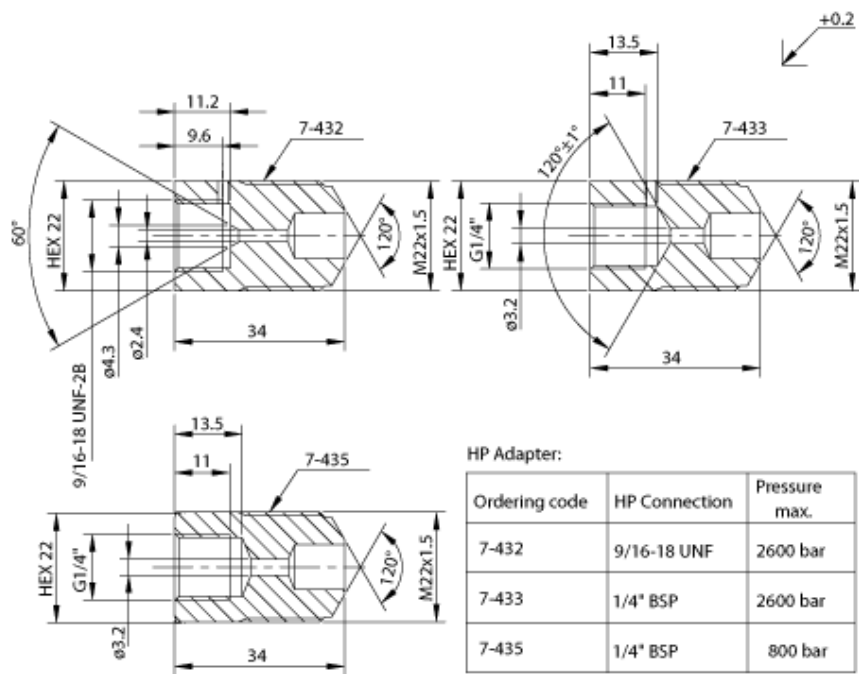

HP Adapter:

Ordering code	HP Connection	Pressure max.
7-432	9/16-18 UNF	2600 bar
7-433	1/4" BSP	2600 bar
7-435	1/4" BSP	800 bar

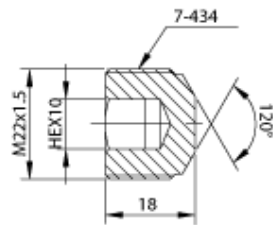

HP Plug:

Ordering code	Pressure max.
7-434	2600 bar

7-900 / Issue 1

▲ **Fluids and materials**

Please see [General Specifications](#).

▲ **Ordering a HC7W**

Ordering example of a HC7W with  $i = 13.0$ , H1 M22 x 1.5 and H2 19/16-18 UNF.  
DV incorporated and BSP connections:

HC7W - 13.0 - B - 12 For media < 5 cSt ( $\text{mm}^2/\text{s}$ ) tested in water

HC7W - 13.0 - B - 12S For media > 5 cSt ( $\text{mm}^2/\text{s}$ ) tested in hydraulic oil

**Please note!**

High pressure adapter ordering code – see table

<b>Model</b>	<b>Intensification, <math>i</math></b>	<b>Dump Valve</b>	<b>Connections</b>
HC7W	your selection...	your selection...	see table below
	see <a href="#">flow rate table</a>	A = (no) / <a href="#">A model</a>	
		B = (yes) / <a href="#">B model</a>	
		G = (proportional) / <a href="#">G model</a>	

<b>Ordering Code</b>	<b>IN, R</b>	<b>H1</b>	<b>H2</b>	<b>H3</b>
HC7W-__-__-11	1/4" BSP	M22 x 1.5	-	-
HC7W-__-__-21	7/16-20 UNF	M22 x 1.5	-	-
HC7W-__-__-12	1/4" BSP	M22 x 1.5	9/16-18 UNF	-
HC7W-__-__-22	7/16-20 UNF	M22 x 1.5	9/16-18 UNF	-
HC7W-__-__-13	1/4" BSP	M22 x 1.5	9/16-18 UNF	9/16-18 UNF
HC7W-__-__-23	7/16-20 UNF	M22 x 1.5	9/16-18 UNF	9/16-18 UNF

ISO 9001  
BUREAU VERITAS  
Certification

