

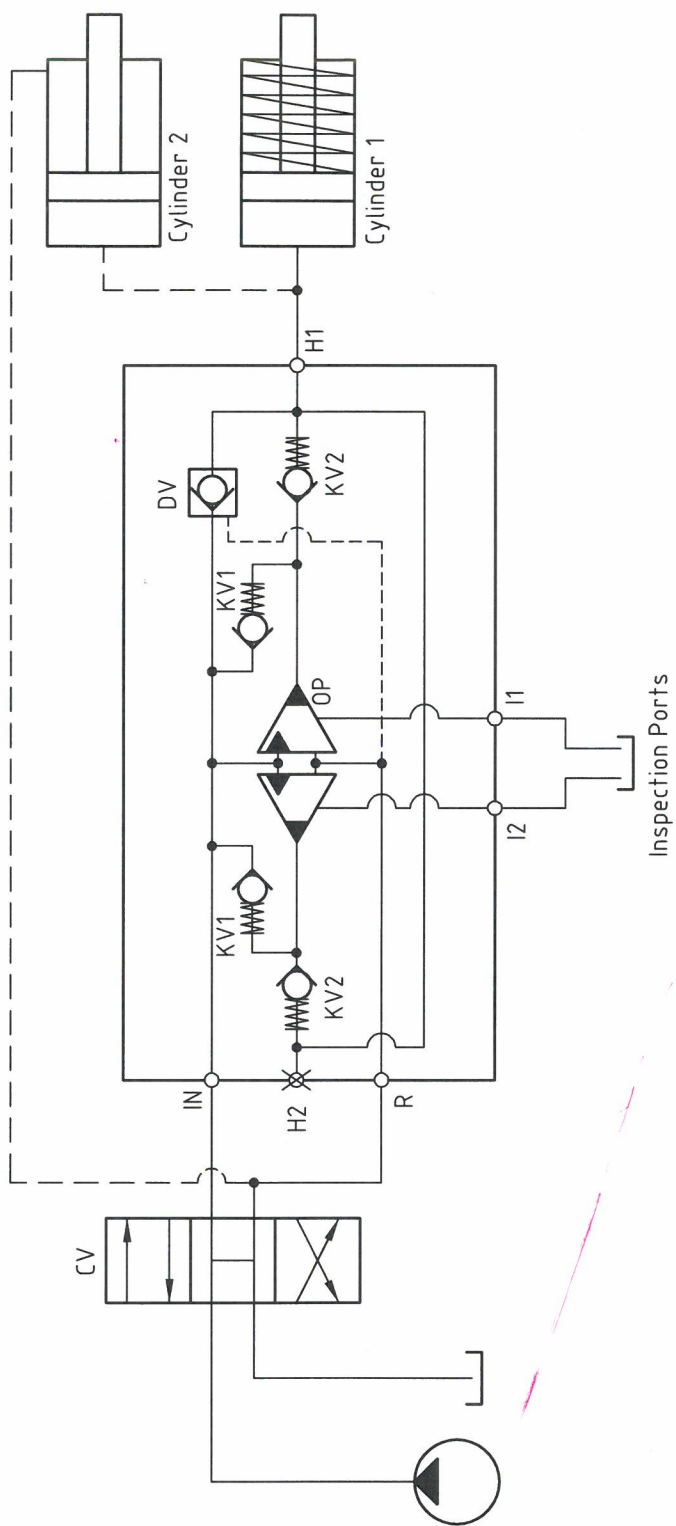

(✓) ✓



Assembly Drawings:
2DW-120-0
2DHW-120-0

Number	Designation	Material	Dimension	Issue	Matr. code No.
Changes		Date	Name	Ext. dim.:-, Int. dim.:+, Distance.:±	Surface
Ass. draw. No. added		11.05.2017	L.H.		Break all edges
				Meas. -range	0-6 6-30 30-100 100-300 300-1000
				2 dec. ,00	0.05 0.10 0.15 0.20 0.30
				1 dec. ,0	0.10 0.20 0.30 0.50 0.80
				No dec.	0.30 0.50 0.80 1.20 2.00
Replace		Scale	HC2D(H)W Funktionsdiagram		Confidential: Property of miniBOOSTER, HYDRAULICS A/S Denmark Not to be handed over to, copied or used by third party.  No.: 2DW-105-02
Designer	Leif Hansen		HC2D(H)W Function Diagram		
Konf.			HC2D(H)W Funktionsdiagramm		
Date	02.10.2012				