

Max. outlet pressure: 500 bar
 Max. bypass flow 100 l/min.
 Standard coil voltage: 12 VDC; other voltage available on request

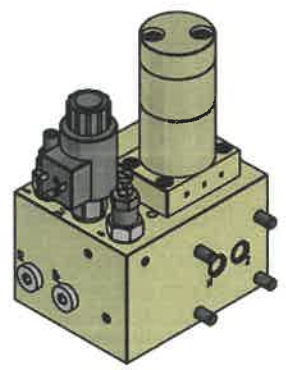
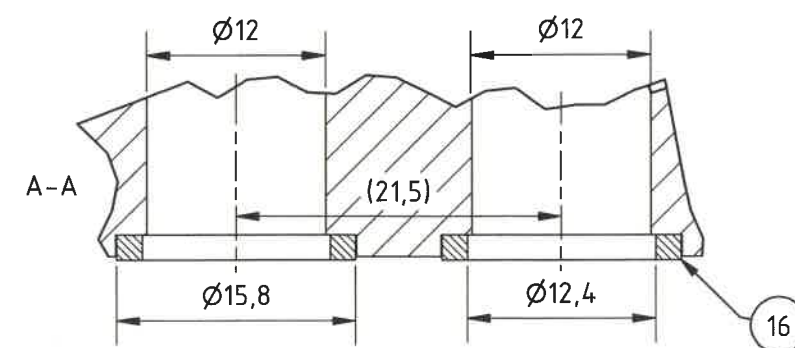
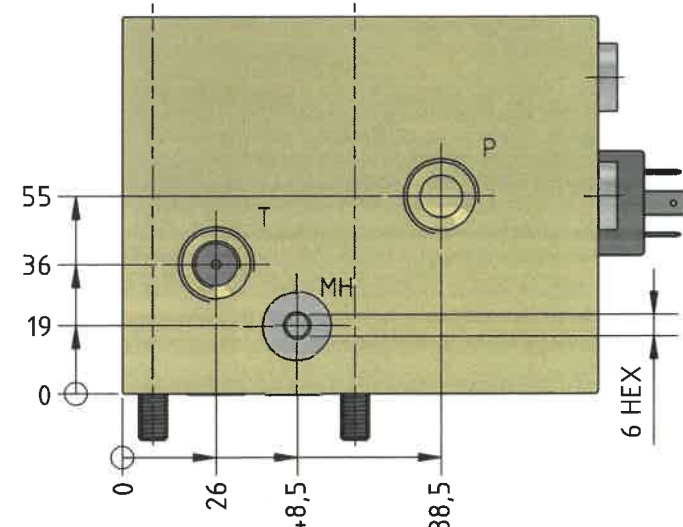

(1:5)

PARTS LIST			
ITEM	QTY	PART NUMBER	DESCRIPTION
1	1	HC3-___-A-D	Hydraulic Booster
2	1	3-028	Manifold
3	1	W-PFA11A3D0340N-WN	Solenoid Directional Valve
5	1	W-PB11A-30AL	Pressure Reducing Valve (7-210 bar)
6	1	CMV 1B 500	Relief Valve (0-500 bar)
16	2	3-610	K.S.BU7 12,4x15,78x1,68 NBR90
100	4	2D-614	Bolt M8x110 12,9 DIN 912

Port connections:
 P & T: 1/2" BSPP
 H & Z: Section view A-A
 M: 1/4" BSPP

Material		Issue	Material Code No.
Changes		Date	Name
Former drawing No.: M-HC3-012-FK55-00		18-05-2021	L.H.
			Finish
			Break all edges
			Hardening depth
			HV
Designer	Leif Hansen	Scale 1:2	M-HC3-012-FK100
Approved by	<i>[Signature]</i>	Format A3	Intensifier System
Date	05-03-2021		Assembly Drawing
			<small>Confidential: Property of miniBOOSTER HYDRAULICS A/S Denmark Not to be handed over to, copied or used by third party.</small>
			Drawing No.: M-HC3-012-FK100-01